

# CIK / MSA Differences in the KF3 Class

## Content

- **Wheels, Tyres and Rear width**
  - Wheel size
  - Tyre size / Type (*homologated*)
  - Rear width (*136cm*)
- **Rear protection**
  - Plastic rear protection
- **Weight**
  - Minimum kart weight
- **Fuel**
  - Minimum amount allowed
  - Fuel standard
- **Carburettor**
  - Any homologated carburettor
- **Exhaust**
  - Noise limit (*100DB/A*)
- **Data Logging**
  - Further restricted to what can be recorded
- **Safety Equipment**
  - Helmet (*CMS / CMR*)
  - Overalls (*CIK Level 2*)

MSA Yearbook

MSA Kart Yearbook

CIK Yearbook

## Wheels, Tyres and Rear Width

### **B2.5 Tyres.**

Slick - Bridgestone YGB, Front 10 x 4.5 x 5, Rear 11 x 7.1 x 5 (or 11x6.50x5 if specified in championship regulations in which case the maximum kart width is 1360mm), MSA moulded on the sidewall. Note: from 01.01.2011 the slick tyre will be replaced by a tyre from the list homologated by the CIK for use in the KF3 class.

Wet - Bridgestone YEJ Front 10 x 4 x 5, Rear 11 x 6 x 5.

### **B2.3 Chassis.**

The maximum width of the kart is 1400mm if the rear slicks are 7.1 width, otherwise it must be 1360mm (this is a variation on the CIK regulation).

#### **2.22.2.1 – 5" Tyres**

The maximum width of a rear wheel is 215 mm and the maximum width of a front wheel is 135 mm.

In KF3, the maximum width of a rear wheel is 185 mm.

#### **2.4.1 – Technical specifications**

Overall width: 140 cm maximum, except in KF3: 136 cm maximum.

#### **Article 19**

\* Tyres: 5" homologated hard type.

## **Rear Protection**

### **B2.3.1 Bumpers.**

CIK homologated rear protection system or MSA specification rear bumper is permitted in this class.

*(See CIK Drawing 2c attached for dimensions)*

## **Weight**

### **B2.6.1 Weight.**

Minimum 145kg with driver at any time. The minimum weight of the kart (without fuel) to conform to CIK regulations. Maximum kart weight without driver is 105kg at any time.

### **Article 19**

*\* Minimum weight of kart (without fuel): 75 kg.*

## **Fuel**

**16.18** For all Classes, to enable a fuel test to be conducted 3 litres of fuel should be present and a minimum of one litre of fuel must be present at the end of each race. The minimum penalty for failure to have the minimum quantity present is exclusion from the results in that race.

### **B2.4.3 Fuel.**

As per MSA Competitors' and Officials' Yearbook (U16.7). CIK specification fuel is permitted when supplied as a Control Fuel and specifically approved by the MSA in applicable Championship Regulations.

### **2.21.3.2 – Sampling procedure**

The fuel shall be sampled in the presence of an Official designated by the CIK-FIA or the ASN of the Driver or of a representative of the team or of the Entrant. At any time the volume of fuel in the tank must be over or equal to 3 litres.

*(See CIK appendix 4 attached regarding octane)*

## **Carburettor**

### **B2.4.1 Carburettor.**

The only carburettors permitted are the 'VA.MEC Tryton F3 KF3 D20' (CIK homologation number 26/C/15) and the carburettor designated for the current CIK-FIA Championship.

### **Article 19**

\* KF3 homologated butterfly carburettor with a maximum diameter of 20 mm, comprising two set screws; it must remain strictly original. It must comply with the Homologation Form and the tooling deposited by the Manufacturer for the control of the shape of the inlet duct.

For the CIK-FIA Championships, Cups and Trophies, a single carburettor supplier will be designated further to an invitation to tender.

## **Exhaust**

**16.16.10.** Maximum sound levels will be 108 dBA with a microphone set at a height of 1.8m ±0.1m, or 105 dBA with a microphone set at a height of 3.6m ±0.1m above the track.

### **B2.4.2 Exhaust.**

MSA Competitors' and Officials' Yearbook noise levels apply (U16.16).

### **Article 18**

\* Noise limited to 100 dB/A maximum at 7,500 rpm.

## **Data logging**

**B2.6.4** Data Logging is permitted, any information logged may be viewed on request by the scrutineers.

### **2.26.3 – Data logging**

This system, with or without a memory, may permit only the reading of: the engine revs (by induction on the spark plug HT cable), two indications of temperature, the speed of one wheel, an X/Y accelerometer and lap times.

In KF4, KF3, KF2, KZ2 and KZ1 the use of a temperature sensor in the exhaust manifold is free but without modifying either the homologated exhaust or the regulatory dimensions of the manifold.

## **Safety Equipment**

**13.3.3.** For Short Circuits, leather, or suits bearing the CIK homologation label (as per 13.4), are acceptable.

**13.4.2.** Suits homologated by the CIK prior to 1<sup>st</sup> January 1997 are not acceptable.

*(Helmets: See; MSA section (k), Drawing 10.3.1 attached)*

### **3.2) EQUIPMENT SAFETY**

\* Fabric overalls must have a « Level 2 » homologation granted by the CIK-FIA bearing in a visible way the CIKFIA homologation number. They must cover the whole body, legs and arms included. Overalls remain valid 5 years after their date of manufacturing and the homologation (i.e. the period during which they can be produced) is valid for 5 years.

- Snell-FIA CMH (Snell-FIA CMS2007 and Snell-FIA CMR2007), for Drivers under 15 years old (standard recommended from 2008 and mandatory from 1.1.2010).

DESSIN TECHNIQUE N°2c

TECHNICAL DRAWING No. 2c

Protection des roues arrière pour circuits courts

Rear wheel protection for short circuits

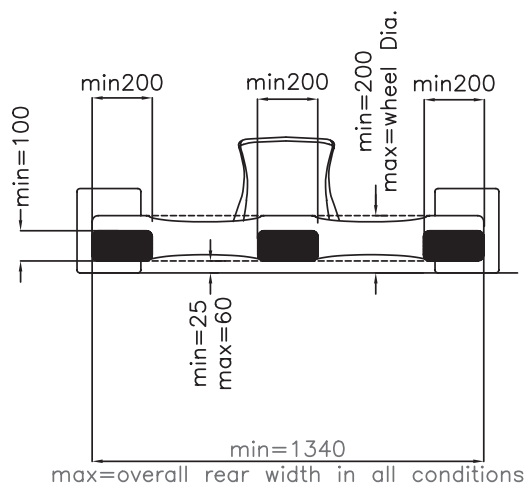

 Vertical surface 0°/-5°

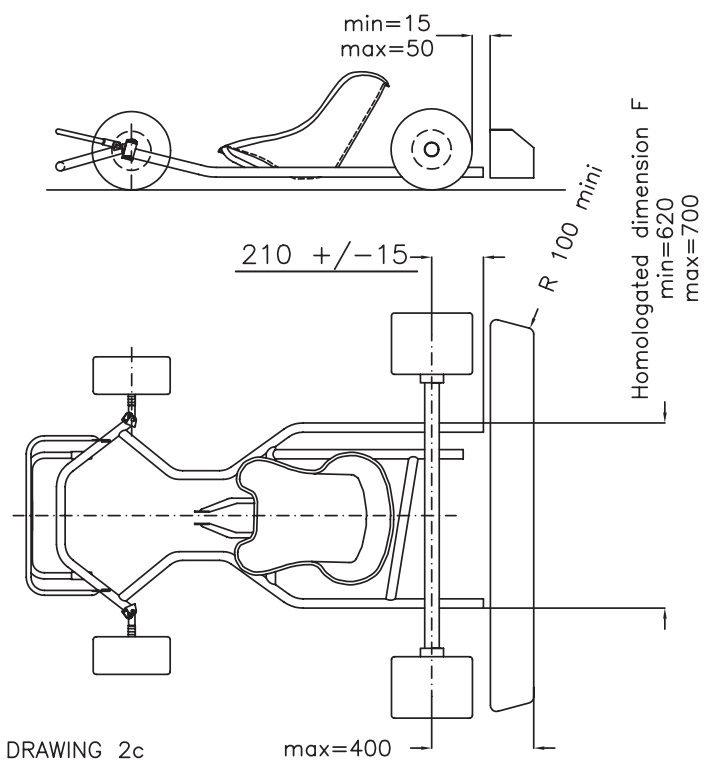

DRAWING 2c  
REAR PROTECTION 2006

\* Dimensions in mm

20.10.2006

**Annexe N°4**

**Appendix No. 4**

**Spécifications du carburant**

**Specifications of the fuel**

<b>Propriétés Property</b>	<b>Unités Units</b>	<b>Minimum Minimum</b>	<b>Maximum Maximum</b>	<b>Méthodes Test Methods</b>
RON		95.0	102.0	ASTM D 2699-86
MON		85.0	90.0	ASTM D 2700-86
Oxygène/Oxygen	%m/m		2.7	ASTM D4815
<i>Analyse Élémentaire Elemental Analysis</i>				
Azote/Nitrogen	%m/m		0.2	ASTM D 3228
Benzène/Benzene	%v/v		1.0	EN 238
TVR/RVP	Kpa		90	ASTM D 323
Plomb/Lead	g/l		0.005	ASTM D 3237
Densité/Density (15°C)	kg/m <sup>3</sup>	720	780.0	ASTM D 4052
Stabilité à l'Oxydation Oxidation stability	minutes	360		ASTM D 525
Gommes actuelles Existent gum	mg/100ml		5	EN 26246
Soufre/Sulphur	mg/Kg		150	EN-ISO/DIS 14596
<u>Distillation</u>				
A/at 70°C	%v/v	10.0	50.0	ISO 3405
A/at 100°C	%v/v	30.0	71.0	ISO 3405
A/at 150°C	%v/v	75.0		ISO 3405
Point Final Final Boiling Point	°C		215.0	ISO 3405
Résidu/Residue	%v/v		2.0	ISO 3405
<u>Composition</u>				
Aromatiques Aromatics	%v/v		35.0*	Chromat. gazeuse Gas Chromat.
Oléfines Olefins	%v/v		18.0*	Chromat. gazeuse Gas Chromat.
Total de di-oléfines Total di-olefins	%m/m		1.0*	GCMS
* Valeurs corrigées en fonction de la teneur en composés oxygénés du carburant * Values corrected according to the fuel oxygenate compounds contained				

Drawing 10.3.1

HELMET STANDARDS



BS 6658-85 Type A/FR



SA2000



SA2005



K98



CMR2007



K2005



SFI 31.1A



SFI 31.2A



FIA